

SCREEN MACHINE INDUSTRIES, INC.

AN AMERICAN MANUFACTURER OF PORTABLE CRUSHING AND SCREENING EQUIPMENT

SPYDER 516T & 512T

US PATENTS
6,698,594
6,669,026



10685 COLUMBUS PARKWAY, PATASKALA, OHIO 43062 USA

1-740-927-3464

1-800-837-3344

WWW.SCREENMACHINE.COM

OVERVIEW

Screen Machine Industries is a global leader in crushing and screening equipment with manufacturing headquarters located near Columbus, Ohio, USA.

Feed hopper can be loaded from three sides (Patent #6,698,594) creating complete jobsite versatility

Open flow design with impact beds on oversized conveyor and feeder carries oversized product in a straight line

USA Made GRADE 80 steel construction for strength and durability



Multiple catwalks and lockable access doors create ease of maintenance

Back hopper panel folds down for direct crusher feed capability

Smooth Start Technology (Patent #6,669,026) prolongs shaker screen life by eliminating violent shaking during warmup and shutdown



Cattron® wireless remote control creates true portability by never having to leave the safety and comfort of the feed operators cab while in control of track movement and machine production

Quality Engineering Requires Industry Leading Brands Such As:

- Eaton
- Weatherhead
- Charlynn
- Browning
- Martin
- Precision
- Prince
- Fairfield
- Sherwin Williams
- Parker
- Torrington
- SKF
- Cattron
- Energy
- Oilair
- Zinga

Specifications Subject To Change Without Notice

UNIQUE FEATURES

THREE SIDED LOADING DESIGN

- Complete jobsite versatility - US Patent #6,698,594
 Designing the placement of the two side conveyors at the discharge end of the shaker screen serves a unique purpose. All three screened product stockpiles are located at the very end of the machine, far away from the feeder hopper. This creates an open area around the feeder hopper on three sides that is unique only to The Screen Machine Spyders. The hopper can now be loaded from either side with a front end loader without the obstruction of material piles. The hopper can also be loaded from the rear with an excavator. Spyders can be set up for any job application, facing any direction without the concerns of finding a way to get material into the hopper.

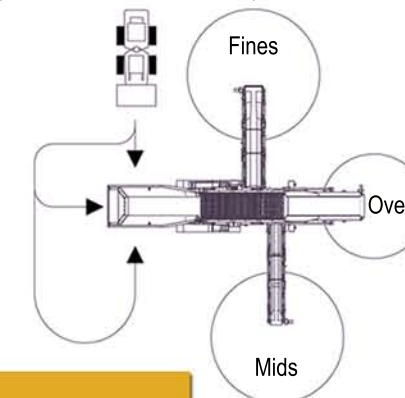

STRUCTURE

- USA Grade 80 steel construction
 All structural supports, feeder hopper, shaker screen and other wear surfaces are manufactured from high strength Grade 80 steel generating a yield strength of 80,000 psi. That's more than two times the yield strength of A36 mild steel (36,000 psi) commonly used in most other portable screening plants. This single feature alone could double your machine's structural life span.
- Massive unibody structure features unrivaled deep frame design
 Massive unibody frame made from Grade 80 steel handles the uneven loading during operation without the need for outriggers or landing gear.
- Elevated frame design equates to rapid deployment and set-up
 9" (229mm) ground clearance uniquely reduces the need for site preparation prior to movement.



SMOOTH START TECHNOLOGY

- **Smooth Start** was designed to completely eliminate the violent shaking that occurs in all screening plants during machine start up and shutdown. Violent shaking during this time period can lead to premature structural stress, cracking, wear and tear on bearings and other vital components, and a reduction in overall life of the machine. Screen Machine Industries is the first and only manufacturer that offers a Smooth Start patented solution.

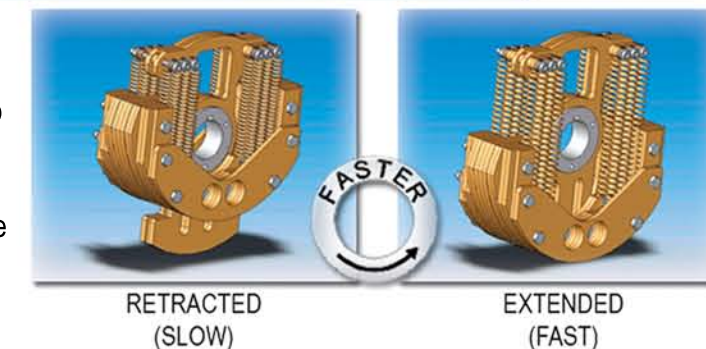

How it works:

At slow speeds, the screen shaft rotates perfectly round, creating zero elliptical throw (no shake at all). As the screen shaft RPM approaches operating speed, the eccentric extends outward creating the appropriate elliptical shake necessary to screen your material. This process also works in reverse during your machine shutdown. Smooth Start technology eliminates the risk of machinery damage caused by slow speed violent shaking during your warm-up or cool-down periods. This fine example of American ingenuity is patented to deliver exclusive long term value.

516T FEATURES

FEEDER

- Feed hopper can be loaded from all three sides
Patented design allows your loader to feed both hopper sides and rear
- Hopper walls made of 1/2" (13mm) USA Grade 80 steel
Hopper strength and durability can handle the toughest applications
- 10'-2" (3m) Feed height at low hopper end
Low hopper feed height permits loading without building a ramp
- Heavy-duty impact bed with impact idlers
1 1/2" (38mm)- thick UHMW plastic liners & 5" (130mm) impact idlers reinforce strength to handle a wide range of raw materials
- 48" (1.22m) Wide 3 ply 600 PIW conveyor belt
- Variable feeder speed adjustment via wireless remote
The safety and control of overall productivity is piloted by wireless remote control from upwards of 300 feet (91m) away
- Dual motor drive with 18" (460mm) lagged head pulley
Horsepower combined with traction equals a steady uninterrupted feed
- Feed height lowers to 8'-3" (2.5m) when rear hopper gate is lowered
The backside of the Spyder hopper folds down creating a low height opening for any SMI crusher conveyor belt to discharge material designated for screening. The crusher and the Spyder operate on the same level ground without the need to build any ramps or steps creating true tracked portability.
- 11 Cu yd (8.4cu m) hopper capacity with a feed area of 15'-6" x 7'-6" (4.7m x 2.3m)
Matches with 4-6 cu yd (.9- 3.7m) front end loaders & 1-3 cu yd (.9-2.75m) excavators
- Optional steel apron feeder
A steel apron feeder is available in place of the conveyor belt when large quantities of re-bar or other sharp metals are prevalent in the raw material.

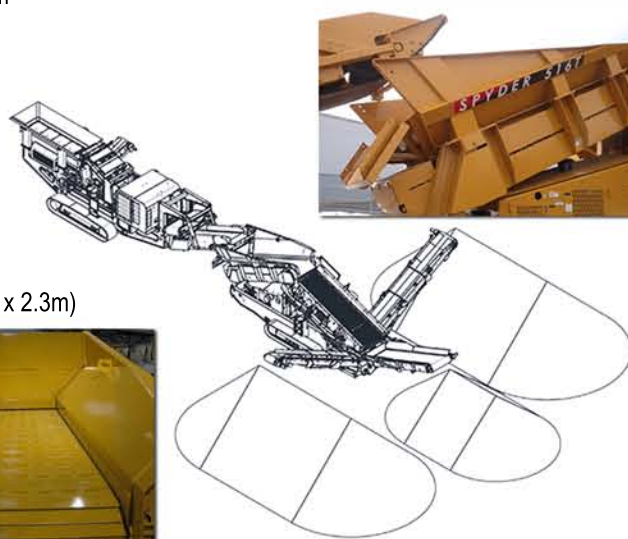

SCREEN BOX

- 5'-0 x 16'-0" (1.5 x 4.9m) double deck two bearing screen
Capacity matched to upwards of 600 tons (544mt) per hour, subject to material specifications
- Shaker screen shaft spins at 1000 RPM creating a perfect screening platform
Unequaled speed and throw combination
- **Smooth Start®** technology used in warm-up & shut-down operations
- 3/8" (9.5mm) Grade 80 US steel screen box for unmatched durability
- Hydraulically adjustable screen angle
Four Positions Ranging From 8 to 20 Degrees
Match the screen angle to material for efficient screening of all types of products
- Top deck 5' x 16' (1.5 x 4.9m) accepts wire cloth, punch plate, grizzly or finger screens
- Bottom deck 5' x 14' (1.5 x 4.3m) accepts wire cloth, harp style or finger screens
- Screen box separates from unders conveyor to create a working platform
This service-minded design creates easy accessibility for changing bottom deck screens
- Heavy-duty ladder and catwalk accessibility
- Quality engineering by design includes all areas of safety and maintenance



512T FEATURES

FEEDER

- Feed hopper can be loaded from all three sides
Patented design allows your loader to feed both hopper sides and rear
- Hopper walls made of 3/8" (10mm) USA Grade 80 steel
Hopper strength and durability can handle the toughest applications
- 10'-9" (3.2m) Feed height at low hopper end
Low hopper feed height permits loading without building a ramp
- Feed height lowers to 8'-10" (2.7m) when rear hopper gate is lowered
Direct feed from a crusher is supported - our 4043T Impact Crusher and JXT Jaw Crusher fit perfectly
- Heavy-duty structural steel impact bed supporting
1" (25mm) Thick UHMW Plastic Liners & 5" (13cm) impact idlers reinforce strength to handle a wide range of raw materials
- 36" (.9m) Wide 3 ply 330 PIW conveyor belt
- Variable feeder speed adjustment
- Hydraulic motor drive with 16.75" (425mm) lagged head pulley
Horsepower combined with traction equals a steady uninterrupted feed
- 8.5 Cu yd (6.5 cu m) hopper capacity with a feed area of 14'-9" x 6'-7" (4.5m x 2.0m)
Long enough for a front end loader, wide enough for an excavator
Matches with 3-5 cu yd (2.5-4.0 cu m) front end loaders & .75-2 cu yd (.5-1.5 cu m) excavators



SCREEN BOX

- 5'-0 x 12'-0" (1.5 x 3.7m) Double deck two bearing screen
Capacity matched to upwards of 400 tons (363mt) per hour, subject to material specifications
- Shaker screen shaft spins at 1000 RPM creating a perfect screening platform
Unequaled speed and throw combination amongst similar designs
- **Smooth Start®** technology used in warm-up and shut-down operations
- Grade 80 US steel screen box
- Hydraulically adjustable screen angle includes four operating positions ranging from 8 to 20 degrees
Match the screen angle to material for efficient screening of all types of products
- Top deck 5' x 12' (1.5 x 3.7m) accepts wire cloth and punch plate screens
- Bottom deck 5' x 12' (1.5 x 3.7m) accepts wire cloth and harp style screens
- Heavy-duty ladder and catwalk accessibility
Quality engineering by design includes all areas of safety and maintenance
- Screen box separates from unders conveyor to create a working platform
This service-minded design creates easy accessibility for changing bottom deck screens



ADDITIONAL FEATURES

POWER SYSTEM & CONTROLS

- 516T features Cummins® Tier III four cylinder 110 HP (82.5 kw) diesel engine
- 512T features Yanmar® Tier IV four cylinder 84 HP (58.83 kw) diesel engine
- 75 gallon fuel tank (284 liters) with lockable fuel cap
 The 516T gets two full days of production as approximate runtime is 17 hours.
 The 512T gets almost three days of production as runtime is approximately 22 hours.
- 120 gallon (454 liters) hydraulic tank is baffled and lockable
- Oilair® hydraulic oil cooler
 From large hose diameters and fittings to baffled tanks and coolers, our hydraulics run cool so your productivity can run hot!
- Five (5) emergency stops (includes one on the wireless remote handset)
- Lockable control panels & electronic Murphy® shut offs
- Large engine compartment for ease of maintenance (large enough to stand upright inside)
- Independent hydraulics
- Cattron® Wireless Remote Control With 300 Ft (91m) Range

Wireless Remote Means Never Having TO Leave The Safety of the Loader Cab To Reposition and Resume Material Processing



CONVEYORS

- Side stackers feature variable height adjustment
 36" Belt for fines conveyer
 24" Cleated belt for midsize conveyer
- All discharge conveyor belts feature variable speed control
 Match belt speeds with your belt angle for optimum stockpiling capability
- Cleated midsize and oversize conveyor belts
- Impact bed on oversize conveyor accepts oversized rocks without concern
 48" Cleated oversize conveyor belt on 516T
 36" Cleated oversize conveyor belt on 512T
- Guide rollers on all conveyor belts
 Guide rollers ensure centered belt tracking, eliminating spillage, damage and downtime
- Transition chutes made of USA Grade 80 steel
- Precision® 5" (127mm) diameter sealed for life idlers
- Precision® rubber disc return idlers (great for sticky materials)

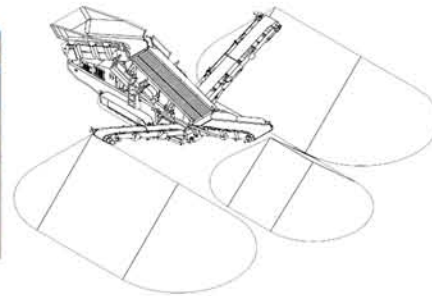

UNDERCARRIAGE

- 20" (500mm) shoe width for low ground pressure
- Sealed and lubricated pins and bushings
- Carrier rollers (one per side)
- Wide track gauge creates outstanding turnability



PRODUCT SUPPORT

- Factory headquarters located near Columbus, Ohio, USA
- Lifetime engineering telephone support at no charge
- Rapid response parts availability
- Name brand parts, internationally recognized and easily sourced
- Extensive distributor network
- Detailed operational, service & parts manuals

Specifications Subject To Change Without Notice

516T DIMENSIONS

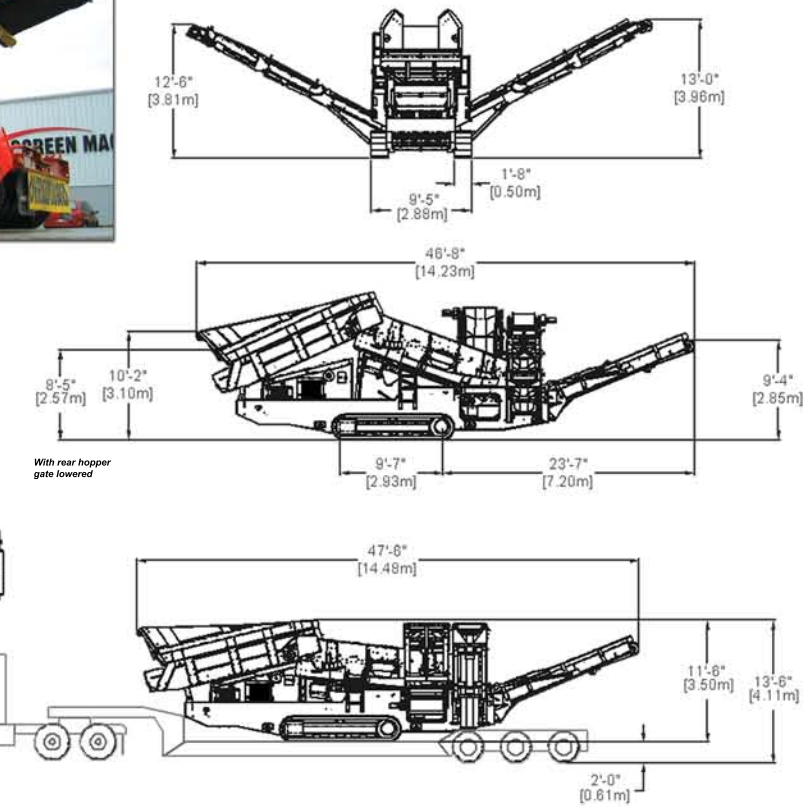
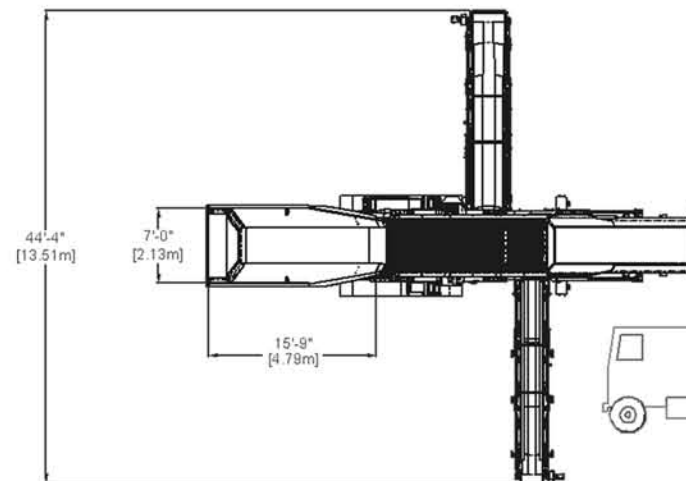

Approx. Weight: 58,000 lbs.

512T DIMENSIONS

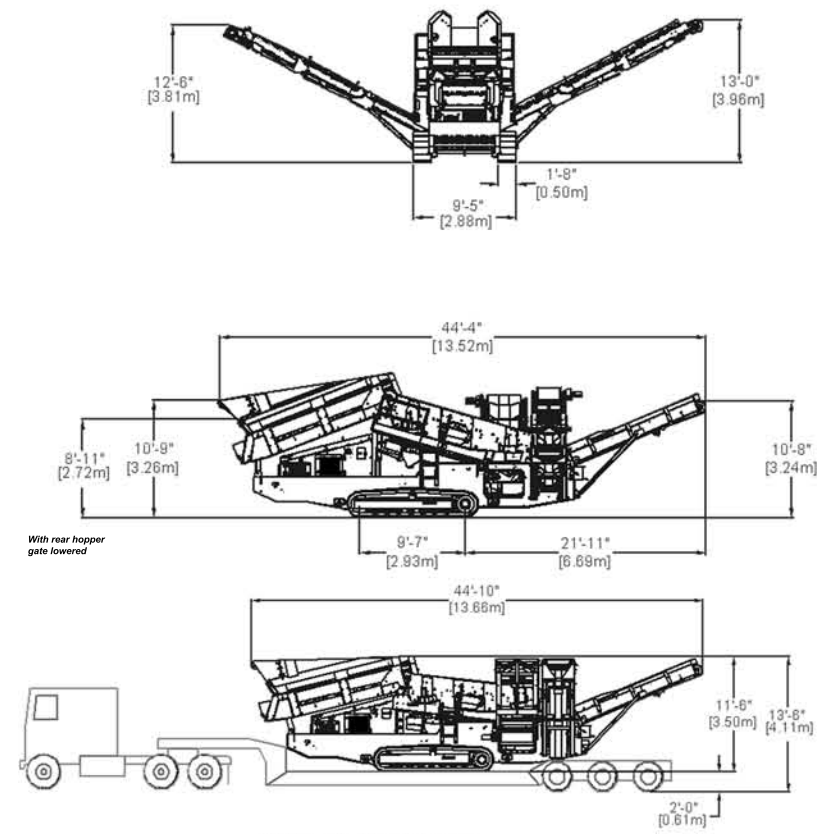
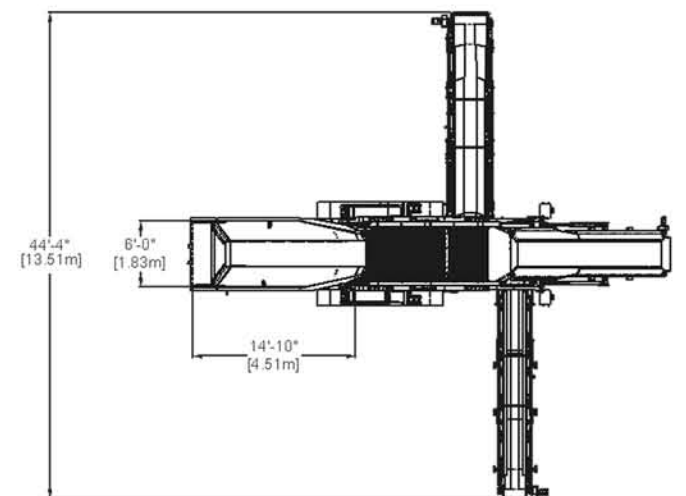

Approx. Weight: 51,000 lbs.

SCREEN MACHINE INDUSTRIES, INC.

AN AMERICAN MANUFACTURER OF PORTABLE CRUSHING AND SCREENING EQUIPMENT

Screen Machine Industries, Inc. is an innovative American manufacturer of portable machinery dedicated to material crushing, screening and stockpiling. Our product offering provides solutions ranging from 15-600 tons/yards per hour across a vast array of applications (such as sand & gravel, concrete & asphalt, topsoil & compost products). Our successful engineering philosophy is to incorporate reliable brand name components and industry leading features with the highest quality manufacturing techniques. This philosophy has prominently driven our success since 1966.



Screen Machine Industries, Inc.
Corporate Headquarters

The manufacturing process includes the utilization of CNC fabrication equipment, robotic welders, advanced painting facilities and highly skilled mechanical technicians assembling these machines. Multiple levels of quality control and thorough run-time inspections are in place to ensure the quality and reliability that we demand and that you expect.



Screen Machine Industries, Inc. continues to make substantial investments in research and development. Our highly skilled engineers combined with the latest computer technology, create the most innovative products in the crushing and screening industries. Numerous U.S. Patents have been awarded as a result of our creative ambition in developing machinery that we feel is superior to any in the industry. We also strive to add the best design engineers available to our organization. Our engineers are graduates of MIT and other prestigious universities throughout the United States.



Our diverse product line consists of heavy-duty, track-mounted Jaw and Impact Crushers, Spyders, Scalpers, Trommels and Conventional Screening and Shredding Plants. Our portable stacking conveyors complete the product lineup with sizes available to fit most every job.



SCALPER 107T



612T TROMMEL



SCALPER 107D



4043T IMPACT CRUSHER



JXT JAW CRUSHER

SCREEN MACHINE INDUSTRIES, INC

**10685 Columbus Parkway
Pataskala, Ohio 43062 USA**

1-740-927-3464 800-837-3344 (USA Only)

Email@screenmachine.com

www.screenmachine.com



DISTRIBUTED BY: